

Project 3: 5.8 GHz RF Energy Harvester

ECE 6361: Microwave Design Lab

Objective

The student team will produce a microwave charge pump that converts a 5.8 GHz continuous wave signal to a DC power supply to drive a low-powered light-emitting diode (LED).

Design Specifications

Each student team is expected to design and build a rectifying RF energy harvesting device, capable of operating in the 5.725- 5.850 GHz ISM band. The device must, using only passive components, convert the microwave power into a DC voltage. The key design targets for the device are

- Interfaces with a 50Ω SMA line input
- Lights up the provided diode with a 10 dBm continuous wave 5.8 GHz input

An example of a generic charge pump for microwave-to-DC conversion is shown below:

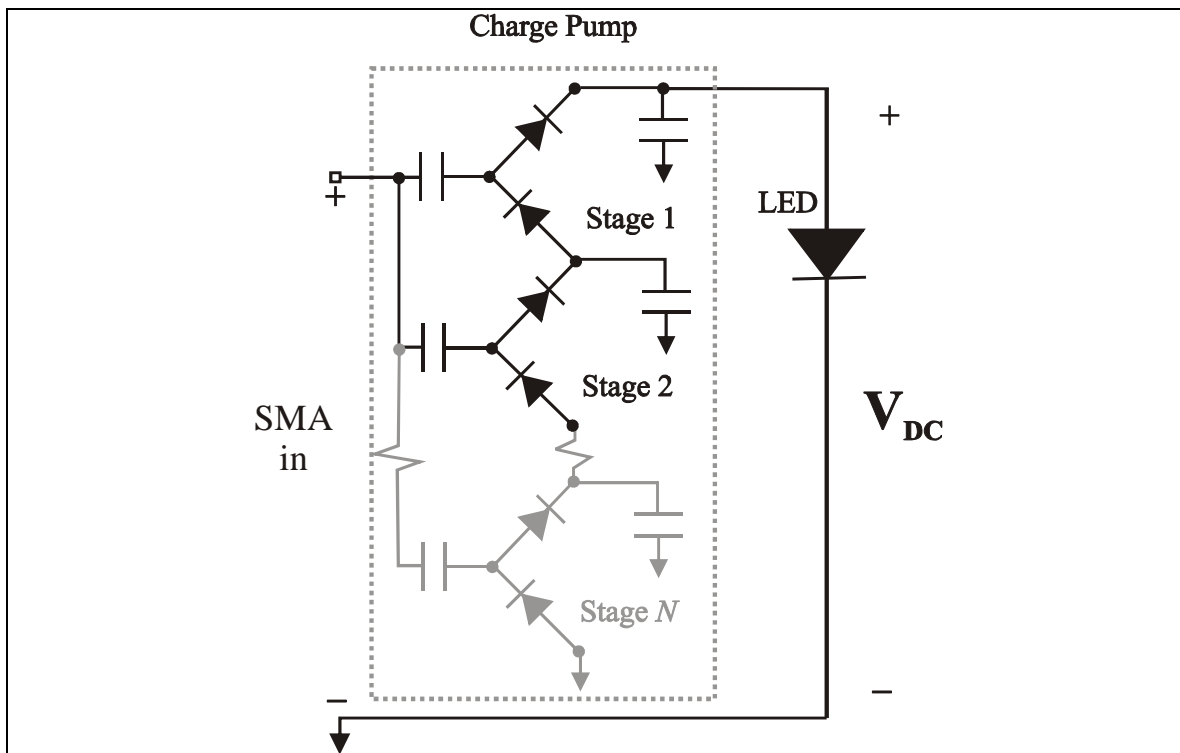

Students are free to incorporate any of the following components: resistors, capacitors, passive RF diodes, stub lines, filters, and any other passive transmission line devices fabricated directly on the printed circuit board.

There is a list of supplies online for building this project. All projects must use the specified diode (provided by the instructor) for the charge pump load.

Printed circuit boards for this design must use the in-house circuit fabrication facilities at Georgia Tech. *Schedule in advance.*

Grading

Grading for the student teams is based on three parts:

1. **Written Report** – The base score of this project will be based on the written documentation of the group’s project design and implementation. Key grading points for good design documentation:
 - a. Technical Correctness
 - b. Thorough Design Methodology
 - c. Clear, *Concise* Writing
 - d. Professional Content
 - e. References

Design documentation should strive for succinct repeatability.

2. **Compliance Test** – Each team must demonstrate to the course instructor that their final device complies with the project specifications. Various project score deductions will be assessed to a team depending on how far “out-of-spec” a final device performs. Compliance may only occur immediately after a scheduled lecture.
3. **Peer Evaluation Forms** – Download the peer evaluation forms from the course site and fill them out for each team member. Various project score adjustments may be assessed to a team depending on peer-assessment of individual team member effort. Form feedback is kept confidential.